

Detail D  
Scale: 2:1

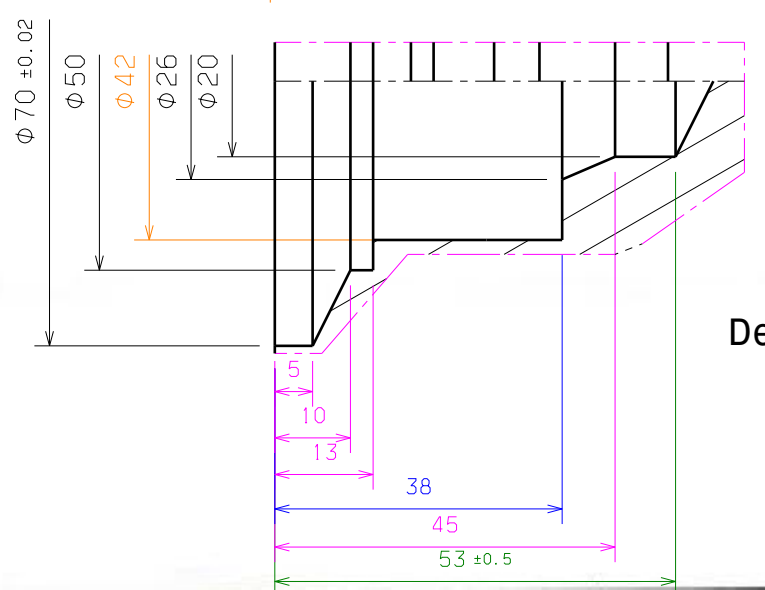

Detail B

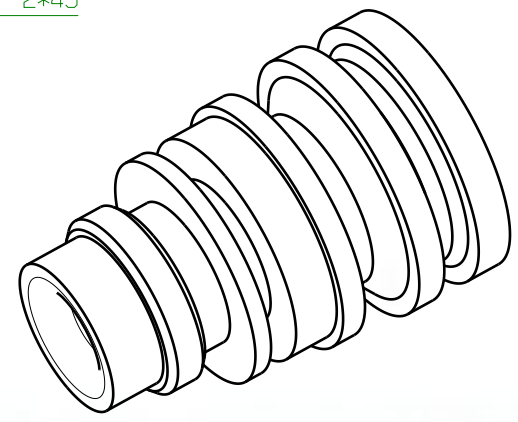

All edge filets  $R=0.2\text{mm}$   
 General tolerance  $\pm 0.1\text{mm}$   
 General tolerance  $\pm 0.5^\circ$  for Angle

1.6 / (3.2 / )

	Checked by:	Material:
	Trade number 6 CNC Turning	= 4.5 hours